

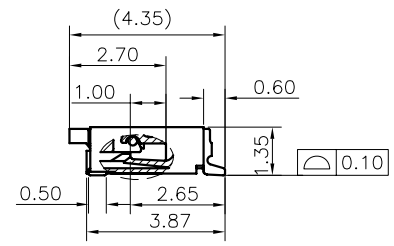

A B C D E F

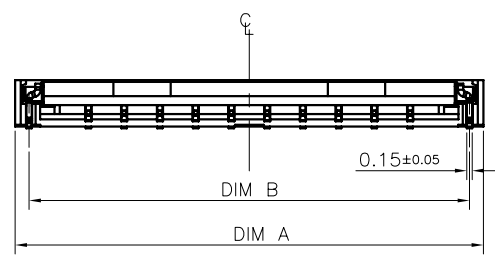
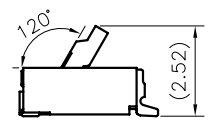
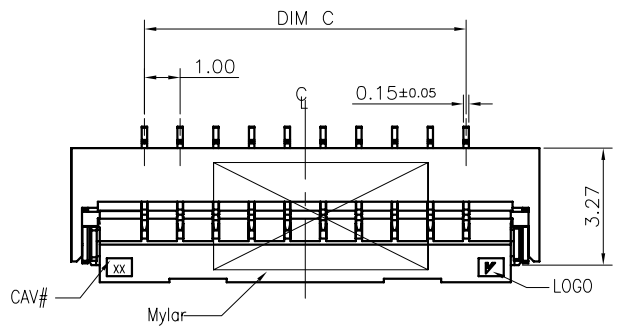

- NOTES:
- MATERIAL:
 - HOUSING: THERMOPLASTIC, HIGH TEMP.,UL94V-0. COLOR:BLCAK.
 - ACTUATOR:THERMOPLASTIC, HIGH TEMP.,UL94V-0. COLOR:NATURAL
 - CONTACT: COPPER ALLOY.
 - FITTING NAIL: COPPER ALLOY
 - FINISH:
 - CONTACT:
 - 50~100u" NICKEL UNDERPLATING OVERALL.
 - 1:GOLD FLASH ON CONTACT, N:80u"MIN. MATTE TIN ON PLATED AREA.
 - SOLDER:
 - 50~100u" NICKEL UNDERPLATING OVERALL.
 - 1:GOLD FLASH ON SOLDER TAILS, N:80u"MIN. MATTE TIN ON PLATED AREA.
 - FITTING NAIL:
 - 50~100u" NICKEL UNDERPLATING OVERALL.
 - N:60~120u" MATT TIN PLATING ON SOLDER TAILS,
 - REFLOW SOLDER CAPABLE TO 260°C PER ACES SPEC.
 - SPEC.PLS REFER TO PS-51503-XXXXX-XXX
 - PACKAGE PLS REFER TO 51574-XXXXX-XX-TRP 51574-XXXXX-00-TRP

6. PART NUMBER

51574-XXX X X-XXX

XXX	HOUSING COLOR	ACTUATOR COLOR
001	BLACK	NATURAL

PACKING 0:TAPE & REEL 4:TAPE & REEL WITH MYLAR

PLATING 1: GOLD FLASH N: MATTE TIN

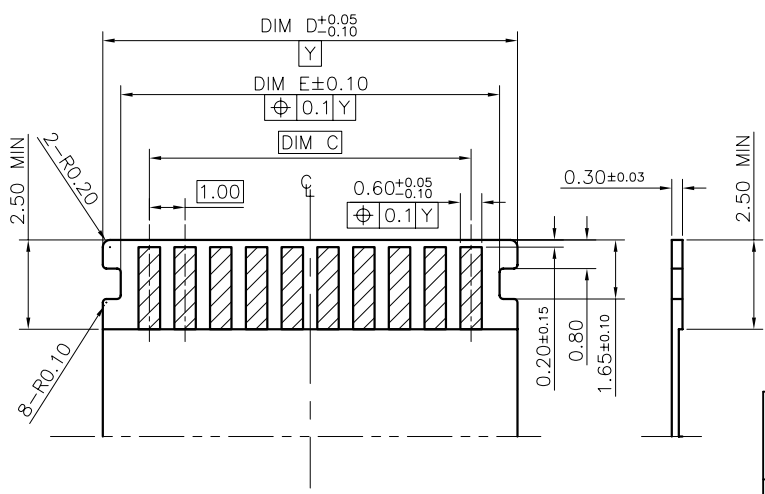
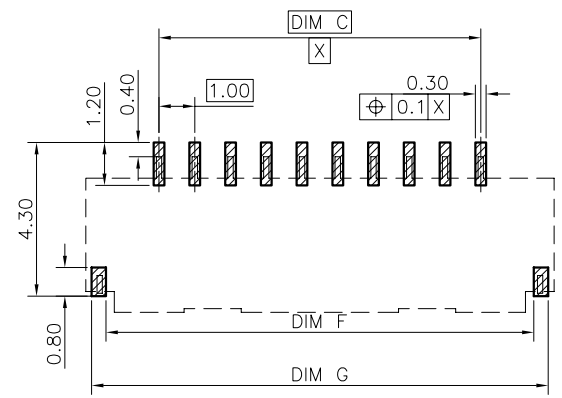
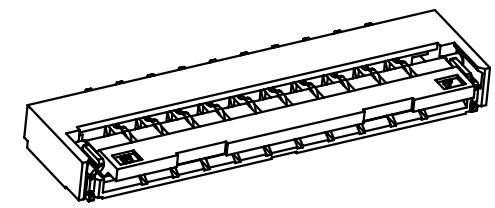

TOLERANCE:±0.05
RECOMMENDED PCB LAYOUT

RECOMMENDED FPC DIMENSIONS
GENERAL TOLERANCE ±0.05

CKT	DIM A	DIM B	DIM C	DIM D	DIM E	DIM F	DIM G	PACKAGE
008	11.10	10.32	7.00	9.6	8.6	9.97	10.77	51574-xxxxx-00-TRP
010	13.10	12.32	9.00	11.6	10.6	11.97	12.77	51574-xxxxx-xx-TRP

一般公差 TOLERANCES X ±0.5 XX ±0.15 X ±0.25 .XXX ±0.1 ANGLES ±2°		宏致電子股份有限公司 Aces Electronics Co.,Ltd.	
檢驗尺寸標示 SYMBOLS ⊕ ⊗ INDICATE CLASSIFICATION DIMENSION ⊕ MARK IS CRITICAL DIM. ⊗ MARK IS MAJOR DIM.	品名 (TITLE) 1.0mm EASY ON FPC CONN. SMT R/A TYPE 圖號 (DWG.NO) 51574-XXXXX-XXX	製圖 (DR) 15/09/26 審核 (CHKD) BRAVE 核准 (APPD) FRANK	XUBIN BRAVE FRANK
表面處理 (FINISH)	比例 (SCALE) 5:1	單位 (UNITS) mm	張數 (SHEET) 1 OF 1 圖號 (DWG.NO) 51574-XXXXX-XXX

A B C D E F